



INFORMATION SHEET

BUILDING SERVICES

Ref: BCA 17-01
Updated at: May 2017

CHANGES TO TERMITE MANAGEMENT OPTIONS FROM 1 MAY 2017

As of 1 May 2017 only the 2014 edition of AS 3660.1 – *Termite Management - New building work* will be able to be used under the Building Code of Australia (BCA) Deemed-to-Satisfy Provisions.

The 2014 edition was referenced in BCA 2015 however the 2000 edition of the standard was also retained for a transitional period to provide industry with time to understand and adapt to the changes.

What has changed?

AS 3660.1 was in need of revision, as significant industry changes have occurred since the publication of the 2000 edition. It was identified that the standard would benefit from further clarity to assist in its application and being amended to address some technical matters that have arisen.

Matters addressed by the revision include:

1. Further clarity regarding the sheet material provisions.
2. Changes in the industry and in the product/solution supply chain related to pipe collars.
3. Current products available for the use of reticulation pipes for distribution of pesticide to soil.
4. The existence of proprietary systems.
5. Service life of chemicals.
6. Current industry practice regarding the use of masonry.
7. Current community expectations related to 'termite management systems' and 'termite barriers'.
8. Current industry practice for the use of glues and space fillers.

One of the more significant changes between the 2000 and 2014 versions is regarding chemical termite management systems. The following is the relevant clause which describes the change:

7.1.1. Soil chemical

"A soil chemical component system shall comply with AS 3660.3. The chemical used shall be registered by the pesticides registrar.

Chemical termite management systems applied under concealed and inaccessible areas shall be replenishable via a reticulation system providing an even and continuous distribution of chemical into the soil."

To understand to this change we need to look at how the BCA provisions apply.

BCA requirements

Part 3.1.3 of Volume Two contains the BCA Deemed-to-Satisfy Provisions for termite risk management for Class 1 and 10 buildings. The intent of these requirements is to provide a termite management system that deters termites from gaining entry to a building via a concealed route.

The BCA requirements apply where:

- the building is constructed in area where subterranean termites are known to present a potential risk of attack, and
- a primary element of the building is subject to termite attack i.e. the building element does not consist of, or a combination of, any of the following material:
 - Steel, aluminium and other metals.
 - Concrete.
 - Masonry.
 - Fibre-reinforced cement.

DISCLAIMER - The above is intended to provide general information in summary form. The contents do not constitute specific advice and should not be relied upon as such. Formal specific advice should be sought by members with respect to particular matters before taking action.

phone 1300 650 620 | fax 1300 655 953 | enquiries@hia.com.au | hia.com.au

- Timber – naturally termite resistant (in accordance with AS 3660.1)
- Timber – preservative treated (in accordance with AS 3660.1).

Where the provisions apply to the subject building, then a termite management system must be selected in accordance with BCA Table 3.1.3.1 (reproduced below) and the system must comply with AS 3660.1.

In simple terms the BCA provisions state what building elements must be provided with a termite management system and AS 3660.1 provides the details of how to comply.

BCA Table 3.1.3.1 ACCEPTABLE TERMITE MANAGEMENT SYSTEMS AND COMPONENTS

Building Element		Termite management or component
Concrete slab-on-ground	Slab perimeter or external wall perimeter	Slab edge exposure
		Sheet material
		Granular material
		Chemical
	Penetrations/control joints	Sheet material
		Granular material
		Chemical
	Areas beneath the slab (see *Note below)	Sheet material
		Granular material
Chemical		
Suspended floors	Sheet material	
	Granular material	
	Chemical	
Attachments to buildings	Termite management system to the attachment or inspection zone	
<p>*Note: The entire area beneath a slab-on-ground must be treated with a termite management system in accordance with this Table when the slab-on-ground is not designed and constructed in accordance with AS 2870 (residential slabs and footings) or AS 3600 (concrete structures).</p>		

AS 3660.1

AS 3660.1 sets out the requirements for the design and construction of subterranean termite management systems. It includes requirements for both physical and chemical termite management systems.

Options are provided so that various approaches may be used either singly, or in combination, to provide an integrated termite management system.

Changes to chemical termite management system requirement

Looking specifically at the change to Clause 7.1.1 in AS 3660.1 2014.

As outlined in the table above one of BCA acceptable solutions includes a chemical termite management system. This can be used for:

- Slab or external wall perimeter edge treatment
- Penetrations and control joints through slabs
- Areas beneath the slab

- Under suspended floors.

The 2014 change to AS 3660.1 requires that for concealed and inaccessible areas, that a chemical system be replenishable via a reticulation system providing an even and continuous distribution of chemical into the soil.

This means that a chemical hand spray treatment will no longer be allowed unless a reticulation system is used to allow for recharging the chemical at a later date.

However, it should be noted that a continuous under slab chemical treatment (or other solution) is only required when the slab is not constructed to AS 2870 or AS 3600 and is not used as a physical barrier.

Any control joints, penetrations through the slab and certain footing slab joints (see Appendix A) would still need to be provided with a termite management system. This could be either a chemical, granular or sheet material.

Due to the change to AS 3660.1 if members no longer wish to use a chemical system, then another acceptable type from BCA Table 3.1.3.1 can be selected.

State and Territory Variations

Both Queensland and Northern Territory have variations to the national BCA termite risk management provisions. The provisions of Part 3.1.3 do not apply in Tasmania.

Northern Territory

In Northern Territory additional care must be taken to protect buildings from termites north of the Tropic of Capricorn due to presence of *Mastotermes darwiniensis* termites.

The Northern Territory variations to the BCA require that the building include *“additional termite risk management measures in areas where Mastotermes darwiniensis termites are prevalent.”*

The Building Advisory Service Branch (NT) has a ‘Building Note’ outlining examples of measures that would provide that additional care. As such the Building Note needs to be read in conjunction with the BCA.

Queensland

Queensland have a number of variations to the BCA provisions. This includes replacing the BCA Acceptable Termite Management Systems and Components table with one specific for Queensland.

As such the changes to AS 3660.1 need to be read in conjunction with the Queensland specific provisions in the BCA.

Which version of the NCC applies to your project?

If you have any doubt about the application of the provisions in your particular state or territory, you should seek advice from your approval authority or State or Territory Building Control Administration.

NOTE: This information sheet addresses the requirements for Class 1 and 10 buildings bearing in mind the requirements for Class 2-9 buildings are almost identical. It should also be noted that this information sheet does not address all of the BCA termite risk management provisions, rather it focusses on the changes resulting from the adoption of the 2014 edition of AS 3660.1.

For further clarification and information on the changes HIA members can contact HIA’s Building Services team on hia_technical@hia.com.au



INFORMATION SHEET

Figure* 1: Footing systems requiring joint treatments

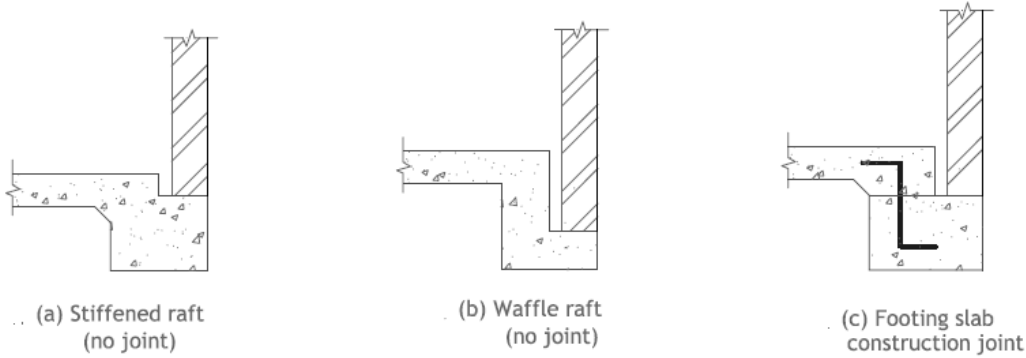

EXAMPLES OF FOOTING SYSTEMS REQUIRING NO JOINT TREATMENT

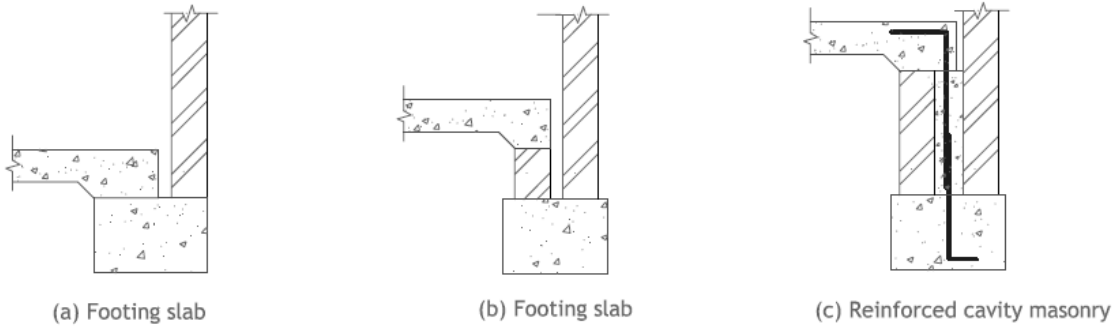

EXAMPLES OF FOOTING SYSTEMS REQUIRING JOINT TREATMENT

The above examples identify footing systems that require a termite management system to the junction/support of the slab. The treatment can include either a chemical, granular material or sheet material. It should be noted that other BCA termite management provisions, such as slab perimeter or external wall perimeter treatment would still apply regardless of whether the footing system requires joint treatment.

* The Figures produced by HIA are based on AS 3660.1.